

T.O.P. USE ONLY:

ASSIGNED: _____

ORDERED: _____

RECEIVED: _____

INSTALLED: _____

INVOICED: _____

**TOWN OF PLOVER
DRIVEWAY CONSTRUCTION PERMIT APPLICATION
AND ATTACHED DRIVEWAY CONSTRUCTION ORDINANCE:**

I, _____, A TOWN OF PLOVER PROPERTY OWNER, HEREBY APPLY FOR A DRIVEWAY CONSTRUCTION PERMIT IN ACCORDANCE WITH ORDINANCE NO. 090701 OF THE TOWN OF PLOVER. A NON-REFUNDABLE FEE OF \$50.00 AND DOCUMENTATION AS INDICATED BELOW IS ATTACHED.

ADDRESS OF SITE: _____

PARCEL NUMBER: _____

CHECK if attached:

____ **1. Sketch Map.** A rough sketch showing the conceptual idea of the project and approximate location and dimensions of the project. The sketch map shall be submitted to the town board prior to the preparation of submission of the other supporting documents in order for the town board to provide initial comments and review of the proposal.

____ **2. Plat Map.** A plat map indicating the location and dimensions of the desired driveway and roadway access locations, if any, as well as the parcels immediately adjacent to the applicant's property. The applicant may first submit only a sketch plat. Once the town board has reviewed the sketch map, the applicant may be asked to submit an additional preliminary plat or final plat, or both.

____ **3. Aerial Photo/Site Analysis.**

____ **4. (Town Board Discretion) Soil/Slope Analysis.**

____ **5. (Optional) Driveway Construction Plan.**

____ **6. (Optional) Roadway Access Location Plan**

____ **7. Other Documents.** The town board may require other documents to be attached to the **Driveway Construction Permit Application.**

I AM AWARE THAT

A. Before any work is done on the parcel, the base of the driveway should be in place and used as the only access to the property.

B. The following minimum specifications shall apply to all new, altered or deteriorating driveways being improved:

1. One driveway is allowed for lots with 200 feet or less of road frontage width.

2. Two driveways are allowed for lots with over 200 feet of road frontage width.

3. A minimum of 200 feet shall separate driveways on same parcel.

4. Deviations from these standards are allowable at the Town Board's discretion.

5. Minimum road surface widths:

a) Residence or duplex – 15 feet to a maximum of 24 feet

b) Business – Town Board's discretion

c) Agricultural – exempt from this requirement

6. Culvert:

a) Size – appropriate length of culvert to meet the 3 to 1 slope– (see 11/20/13 addendum)

b) Type – galvanized or dual plastic.

7. The surface of the driveway connecting with the paved surface of the road shall slope down and away from the road surface in a sufficient amount and necessary distance to prevent ordinary surface water drainage from the driveway area from flowing onto the roadway, and to prevent damage to Town equipment during snow plowing operations.
8. Concrete or asphalt shall be allowed in road right-of-way upon compliance with 1.13 (B) 7.
9. Determination for the need for a driveway 200' or longer to provide a turnaround area for emergency management vehicles will be at the discretion of the town board. (Amendment 11/20/13)
10. All driveway entries onto a town road shall be reviewed by the Town Highway Employee, the Town Board Chair or designee for the possible installation of a culvert. Installation of a culvert is at the expense of the developer or private landowner.
11. Any requirements for culverts shall be based upon slope, ditch depth, water flow and other such criteria upon the discretion of the Town Board.
12. Maintenance of the driveway shall be the sole responsibility of the property owner.
13. No obstructions, i.e. decorative rock walls, lighting, shrubs, garbage cans or fences shall be placed within 12 feet of the pavement edge in the public Right of Way near the driveway to allow for adequate mowing and snowplowing. Trash/recycling containers placed in the road Right of Way shall not exceed 24 hours before or after pick-up times.
14. The Town of Plover assumes no liability for damage occurring in the normal maintenance operation in a Town of Plover Right of Way.
15. All driveways shall be constructed in accordance with the Town of Plover requirements and shall include any other specifications as may be set forth by the Town Board and this ordinance. Joint driveways shall be at the discretion of the Town Board.
16. No change or obstruction of natural drainage water-ways.
17. A fee of \$50.00 shall be charged upon application for a Driveway Permit.

- C. All driveways shall be constructed in accordance with the above requirements and shall include any other specifications as may be set for by the Town of Plover Town Board and this Ordinance. Any driveway on County or State roads needs to be constructed according to the Specifications and regulations of those jurisdictions.
- D. **EVALUATION BY THE TOWN BOARD OF THE DRIVEWAY CONSTRUCTION PERMIT APPLICATION** may include a required site inspection of the proposed driveway, a public hearing and town board meetings. On-site inspections may be conducted by members of the Town Board of Plover as well as members of the Town of Plover Plan Commission if deemed appropriate.

DATE: ____/____/____ SIGNATURE: _____ PHONE: _____

11/20/13 ADDENDUM (SEE SECTION A. 6. (a):

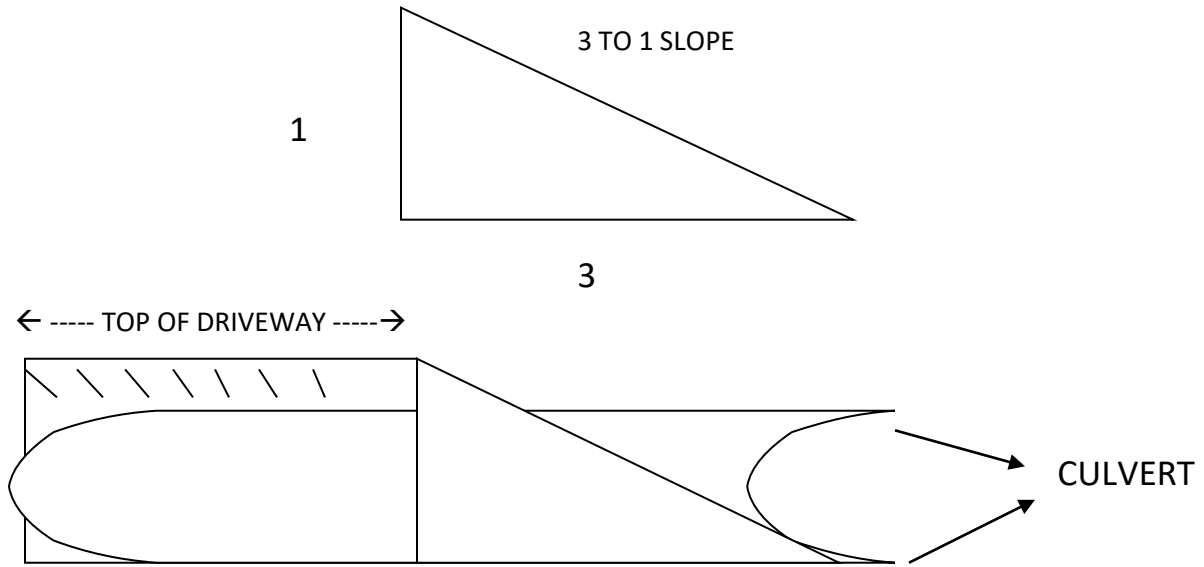

DRIVEWAY SECTION